

ONKYO SERVICE MANUAL

COMPACT DISC PLAYER MODEL DX-220

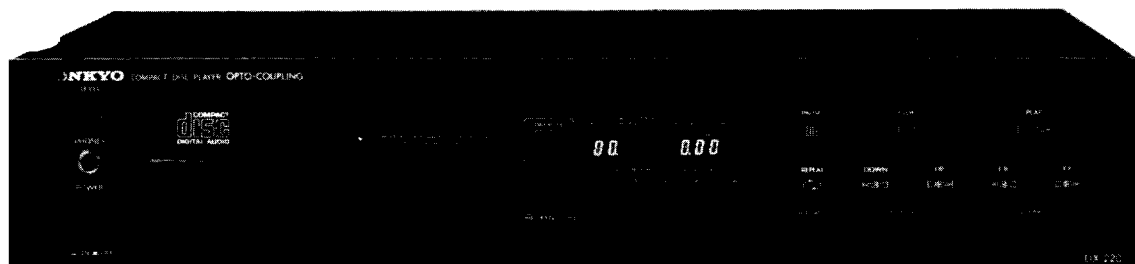

Black and Silver models

BUDN, BUD	120V AC, 60Hz
BUG, UG	220V AC, 50Hz
BUW, BUWX, UW	120/220V AC, 50/60Hz
BUQA, BUQB	240V AC, 50Hz

SAFETY-RELATED COMPONENT WARNING!!

COMPONENTS IDENTIFIED BY MARK Δ ON THE SCHEMATIC DIAGRAM AND IN THE PARTS LIST ARE CRITICAL FOR RISK OF FIRE AND ELECTRIC SHOCK. REPLACE THESE COMPONENTS WITH ONKYO PARTS WHOSE PARTS NUMBERS APPEAR AS SHOWN IN THIS MANUAL.

MAKE LEAKAGE-CURRENT OR RESISTANCE MEASUREMENTS TO DETERMINE THAT EXPOSED PARTS ARE ACCEPTABLY INSULATED FROM THE SUPPLY CIRCUIT BEFORE RETURNING THE APPLIANCE TO THE CUSTOMER.

SPECIFICATIONS

Signal readout system:	Optical non-contact
Reading rotation:	About 500~200 r.p.m. (constant linear velocity)
Linear velocity:	1.2~1.4m/s
Error correction system:	Cross interleave readsolomon code
Decoded bits:	16 bits linear
Sampling frequency:	88.2kHz (two-times oversampling)
Number of channels:	2 (Stereo)
Frequency response:	5Hz~20kHz
Total harmonic distortion:	0.004% (at 1kHz)
Dynamic range:	93dB
Signal to noise ratio:	96dB
Channel separation:	90dB (at 1kHz)
Wow and Flutter:	Below threshold of measurability
Power consumption:	12 watts
Output level:	2 volts r.m.s.
Dimensions (W x H x D):	435 x 88 x 357mm 17-1/8" x 3-7/16" x 14-1/16"
Weight:	4.8kg, 10.6lbs.

Specifications are subject to change without notice.

ONKYO
AUDIO COMPONENTS

PROTECTION OF EYES FROM LASER BEAM DURING SERVICING

This set employs a laser. Therefore, be sure to follow carefully the instructions below when servicing.

WARNING!!

WHEN SERVICING, DO NOT APPROACH THE LASER EXIT WITH THE EYE TOO CLOSELY. IN CASE IT IS NECESSARY TO CONFIRM LASER BEAM EMISSION, BE SURE TO OBSERVE FROM A DISTANCE OF MORE THAN 30cm FROM THE SURFACE OF THE OBJECTIVE LENS ON THE OPTICAL PICK-UP BLOCK.

LASER WARNING LABELS

The labels shown below are affixed.

1. Warning labels

120V model

Laer Diode Properties

- Material: GaAS/GaAlAs
- Wavelength: 780nm
- Emission Duration: continuous
- Laser output: max. 0.4mW*

*This output is the value measured at a distance about 1.8mm from the objective lens surface on the Optical Pick-up Block.

DANGER — INVISIBLE LASER RADIATION WHEN OPEN AND INTERLOCK FAILED OR DEFEATED. AVOID DIRECT EXPOSURE TO BEAM.

CAUTION — HAZARDOUS LASER AND ELECTROMAGBETIC RADIATION WHEN OPEN AND INTERLOCK DEFEATED.

ATTENTION — RAYONNEMENT LASER ET ELECTROMAGNETIQUE DANGEREUX SI OUVERT AVEC L'ENCLICHENEMENT DE SECURITE ANNULE.

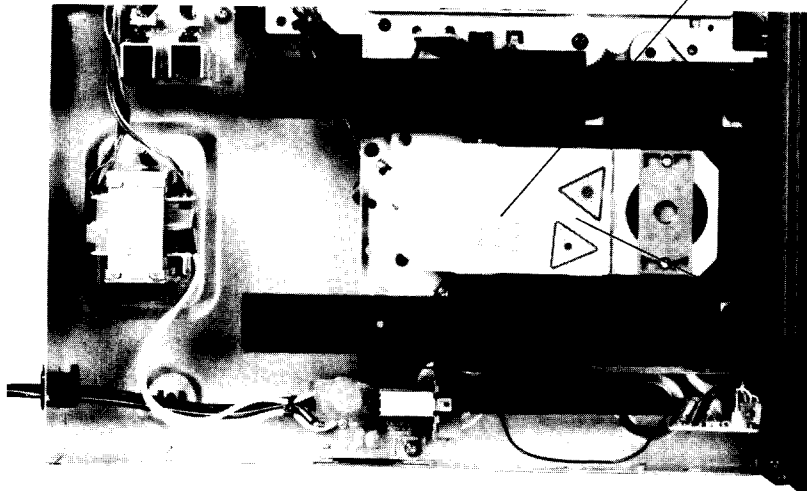

Photo 1

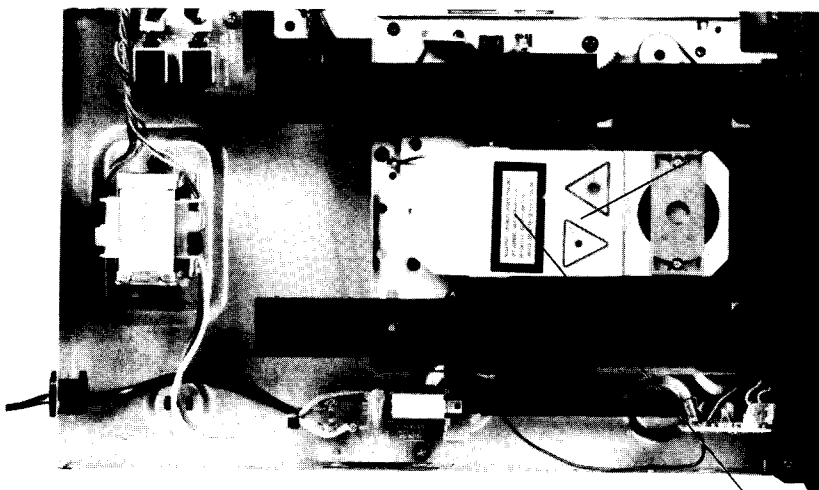
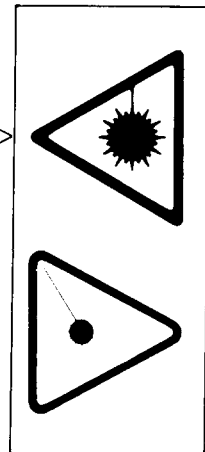

Photo 2



ADVARSEL: USYNLIG LASERSTRÅLING VED ÅBNING, NÅR SIKKERHEDSAFBRYDER ER UDE AF FUNKTION. UNDGÅ UDSÆTTELSE FOR STRÅLING.

2. Certification label (UD: 120V) model

This label is located on the back panel.

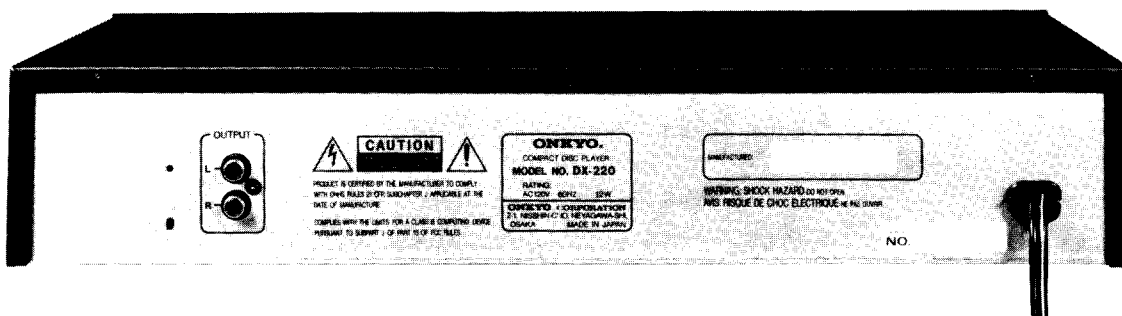

Photo 3

3. Class 1 label (Other models)

This label is located on the back panel.

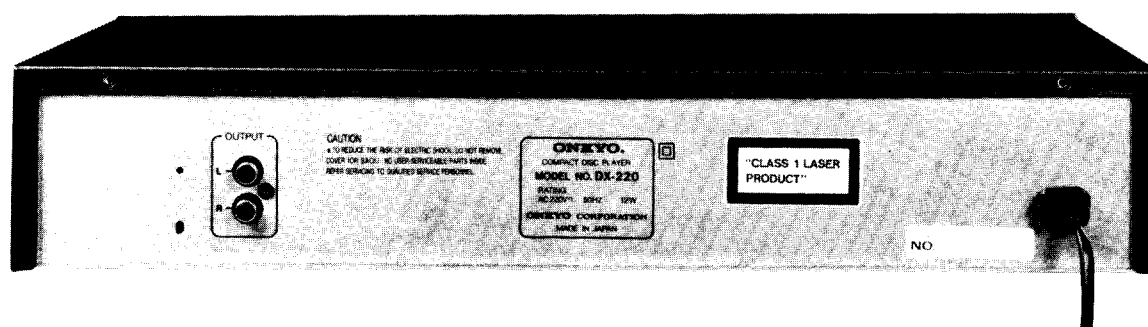

Photo 4

ADVARSEL

"CLASS 1 LASER
PRODUCT"

Denne mærkning er anbragt på apparatets højre side og indikerer, at apparatet arbejder med laserstråler af klasse 1, hvilket betyder, at der anvendes laserstråler af svageste klasse, og at man ikke på apparatets yderside kan blive udsat for utilsadelig kraftig stråling.

APPARATET BØR KUN ÅBNES AF FAGFOLK MED SÆRLIGT KENDSKAB TIL APPARATER MED LASERSTRÅLER!

ADVARSEL: USYNLIG LASERSTRÅLING
VED ÅBNING. NÅR SIKKERHEDSAF-
BRYDER ER UDE AF FUNKTION
UNDGÅ UDSÆTTELSE FOR STRÅLING.

Indvendigt i apparatet er anbragt den her gengivne advarselmærkning, som advarer imod at foretage sådanne indgreb i apparatet, at man kan komme til at udsætte sig for laserstråling.

Fig. 10

EXPLODED VIEW

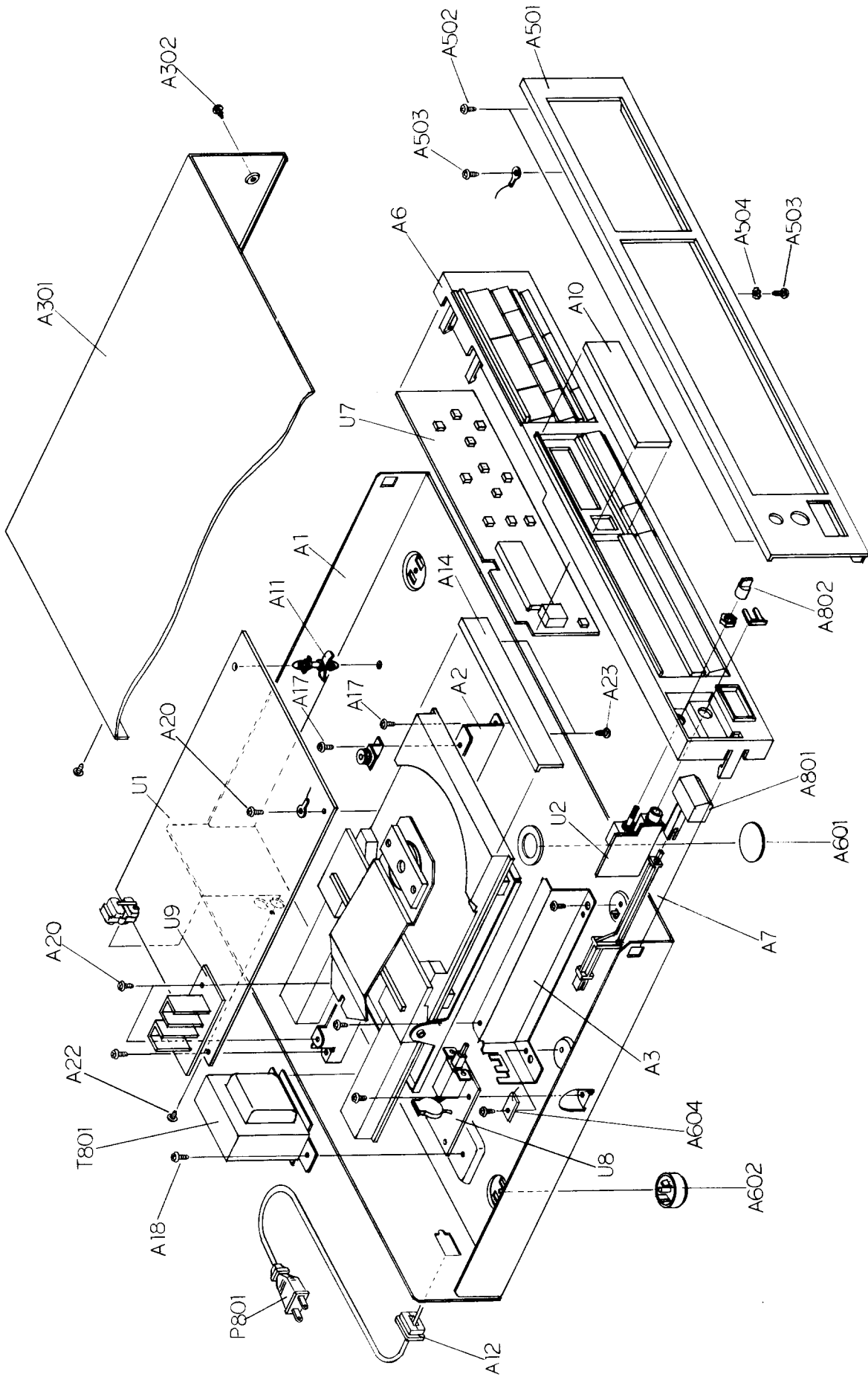

PARTS LIST

REF. NO.	PART NO.	DESCRIPTION	REF. NO.	PART NO.	DESCRIPTION
A1	27100097A	Chassis [D]	P801	253123, 253136 or 253140	AS-JC-6#18, Power supply cord [D/WX]
	27100100A	Chassis [G]		253127 or 253129	AS-CEE 250V, 2.5A, Power supply cord [G/W]
	27100102A	Chassis [W]		253118	AS-SAA, Power supply cord [QA]
	27100112	Chassis [WX]		728328	Power supply cord [QB]
A2	27130441	Chassis [Q]	S802	25065123	NSS-1258P, Voltage selector switch [W]
A3	27130442	Bracket R		82143006	3P+6F(BC), Pan head screw for S802 [W]
A6	271110293	Front bracket ass'y [S]	SC801	2000627	NSAS-8P583, Socket
	271110294	Front bracket ass'y [B]	SC802	2000581	NSAS-8P537, Socket
A7	27273054	Joint	T801	2300167	NPT-943D, Power transformer [D]
A10	28191359	Clear plate		2300169	NPT-943DG, Power transformer [W]
A11	27190011	Holder	U1	10498529-1	NPT-943Q, Power transformer [Q]
A12	27300750	Strainrelief		10498530-1	NAAR-2729-1, Main circuit pc board ass'y
A14	27210738A	Tray panel	U2	10498530-1	NAHP-2730-1, Headphone terminal pc board ass'y [G/Q/W]
A17	834430068	3TTS+6B(BC), Tapping screw		10508530-1A	NAHP-2730-1A, Headphone terminal pc board ass'y [D]
A18	830440089	4TTC+8C(BC), Tapping screw	U7	10498536-1	NADIS-2736-1, Display pc board ass'y
A19	834230108	3TTS+10B(Ni), Nickel screw	U8	10498537-1	NAPS-2737-1, Power switch pc board ass'y
A20	831130088	3TTW+8B, Tapping screw	U9	10498554-1	NAAR-2854-1, Motor driver circuit pc board ass'y
A22	834430108	3TTS+10B(BC), Tapping screw		29360806A	Label, laser
A23	834430080	3TTP+8P(BC), Tapping screw		29360807	Label, danger [D]
A301	28184323	Top cover [S]		29360687	Label, class 1 [G/W/Q]
	28184324	Top cover [B]		29360811A	Label [G/W/Q]
A302	834430068	3TTS+6B(BC), Tapping screw		29360873	Label, locking plate
A501	27210737	Front panel [S]			
	27210739	Front panel [B]			
A502	833430080	3TTP+8P(BC), Tapping screw			
A503	838430068	3TTB+6B(BC), Tapping screw			
A504	87313006	M-3B, Toothed washer			
A601	27270193	Spacer			
A602	27175130	Leg			
A603	834430068	3TTS+6B(BC), Tapping screw			
A604	27141100A	Locking plate			
A801	28322487	Knob, power [S]			
	28322488	Knob, power [B]			
A802	28322650	Knob, level [S]			
	28322437	Knob, level [B]			

NOTE: THE COMPONENTS IDENTIFIED BY MARK Δ ARE CRITICAL FOR RISK OF FIRE AND ELECTRIC SHOCK. REPLACE ONLY WITH PARTS NUMBER SPECIFIED.

NOTE: [B]: Only Black model
 [S]: Only Silver model
 [D]: Only 120V model
 [G]: Only 220V model
 [W]: Only Worldwide model
 [Q]: Only 240V model
 [QA]: Only Australian model
 [QB]: Only U.K. model
 [WX]: Only PX model

MECHANISM EXPLODED VIEW

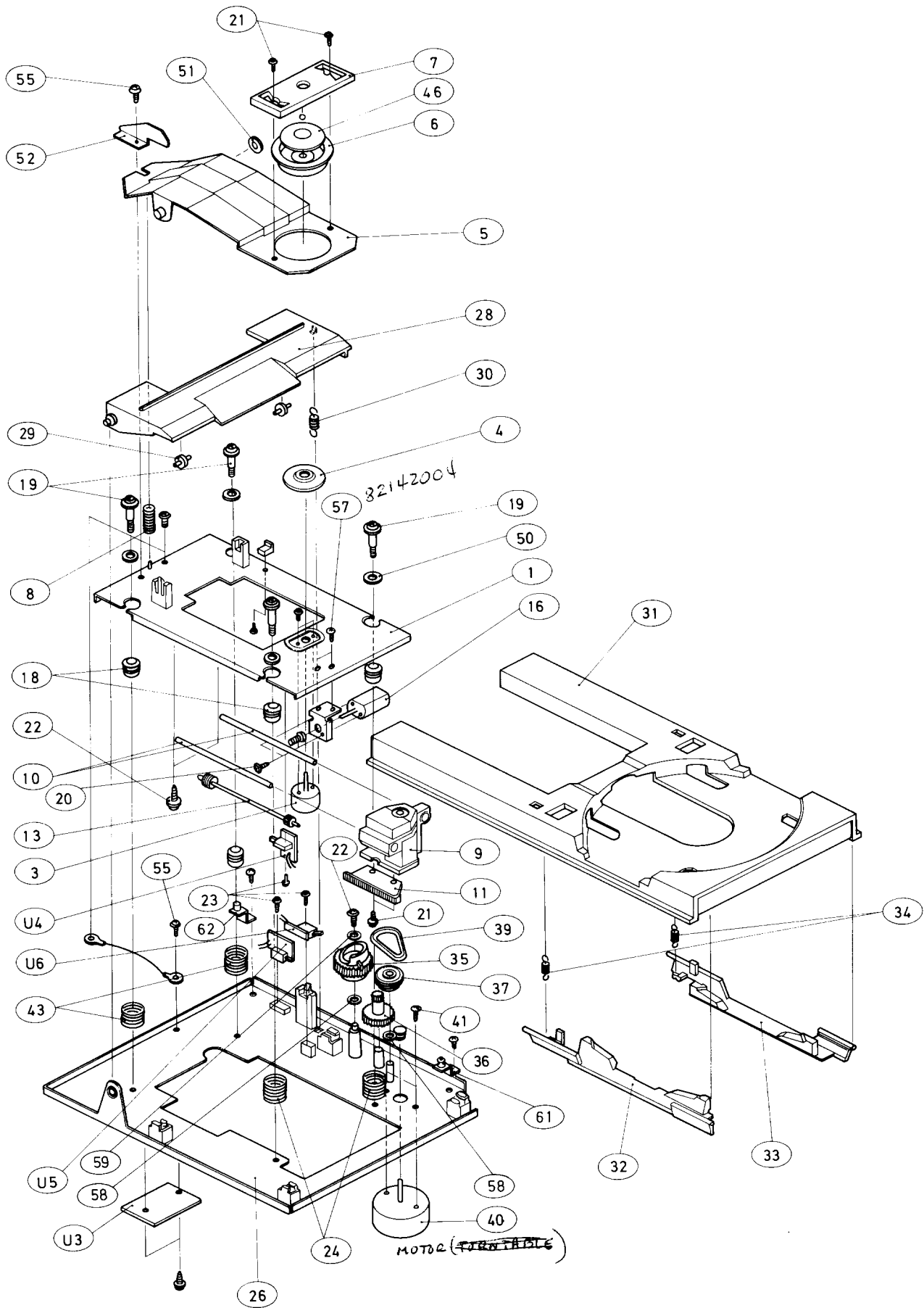

PARTS LIST

REF. NO.	PART NO.	DESCRIPTION
1	27100098E	Chassis
3	24502203	Spindle motor
4	27300846B	Turntable platter
5	27300847A	Arm P
6	27300848A	Cap CH
7	27300849B	Holder, cap
8	27180309A	Spring
9	241065	KSS-123A, Optical pick-up
10	27260222	Shaft
11	27300850B	Rack PU
13	10498902	Shaft ass'y
16	10498903	Motor ass'y
18	27300854	Cushion rubber
19	801364	Special screw
20	82142003	2P+3F (BC), Pan head screw
21	82112605	2.6P+5F, Pan head screw
22	831430100	3TTW+10P (BC), Tapping screw
23	833420108	2TTP+10B (BC), Tapping screw
24	27180319	Spring
26	27100099D	Chassis L
28	27300855E	Arm L
29	27185019A	Roller
30	27180310B	Spring
31	27300861C	Disc tray
32	27300862E	Disc lifter L
33	27300863E	Disc lifter R
34	27180311C	Spring
35	27300856B	Cam gear
36	27300857A	Flat wheel
37	27300858	Pulley gear
39	27300860	Belt
40	10498901	Motor ass'y
41	82142604	2.6P+4F (BC), Pan head screw
42	831430100	3TTW+10P (BC), Tapping screw
43	27180320	Spring
44	833430080	3TTP+8P (BC), Tapping screw
45	833420108	2TTP+10B (BC), Tapping screw
46	27270206	Spacer
47	8930201S	ES-2S, Ring E
50	27270202	φ9, Spacer
51	27270203	φ10, Spacer
52	27141098	Bracket, holder
53	223004-1	Terminal
55	834430068	3TTS+6B (BC), Tapping screw
56	27141098	Bracket, holder
58	27270207	φ7, Spacer
59	27270208	φ4.7, Spacer
61	27180321	Roller spring
62	27180322	Guide ass'y
U3	10498544-1	NATRM-2844-1, Terminal pc board ass'y
U4	10498545-1	NASW-2845-1, Start switch pc board ass'y
U5	10498546-1	NASW-2846-1, Open switch pc board ass'y
U6	10498547-1	NASW-2847-1, Close switch pc board ass'y

DISASSEMBLING PROCEDURES

1. Tray panel removal

- 1) Remove the tray with pressing the OPEN/CLOSE button.
- 2) Turn the unit over and put it on the soft cloth.
- 3) Remove the two screws from the tray.

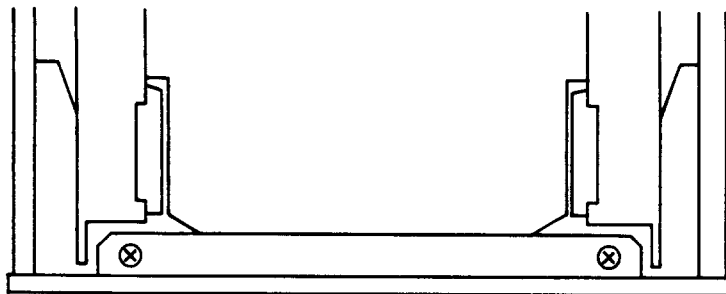

2. Tray removal

- 1) Remove the top cover.
- 2) Open the tray with pressing the OPEN/CLOSE button.
- 3) Release the hook of tray from stopper and pull the tray out.

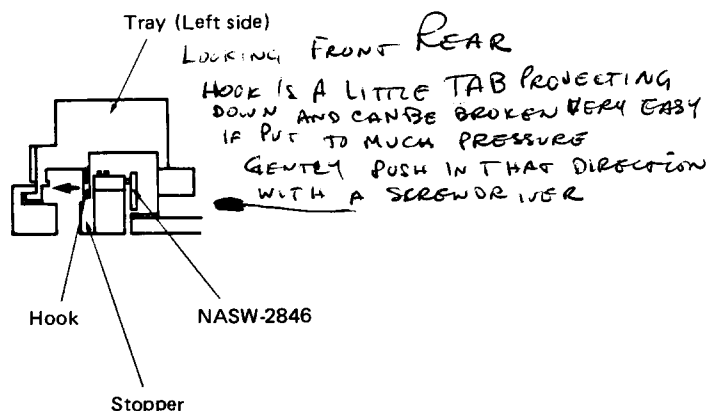

3. Mechanical chassis removal

- 1) Remove the top cover and tray.
- 2) Remove the two screws A from the mechanical chassis.
- 3) Remove the two connectors (P101 & P102) from the main pc board.
- 4) Pull the mechanical chassis out carefully.
- 5) Remove the two connectors (P201 & P202) from the terminal pc board.

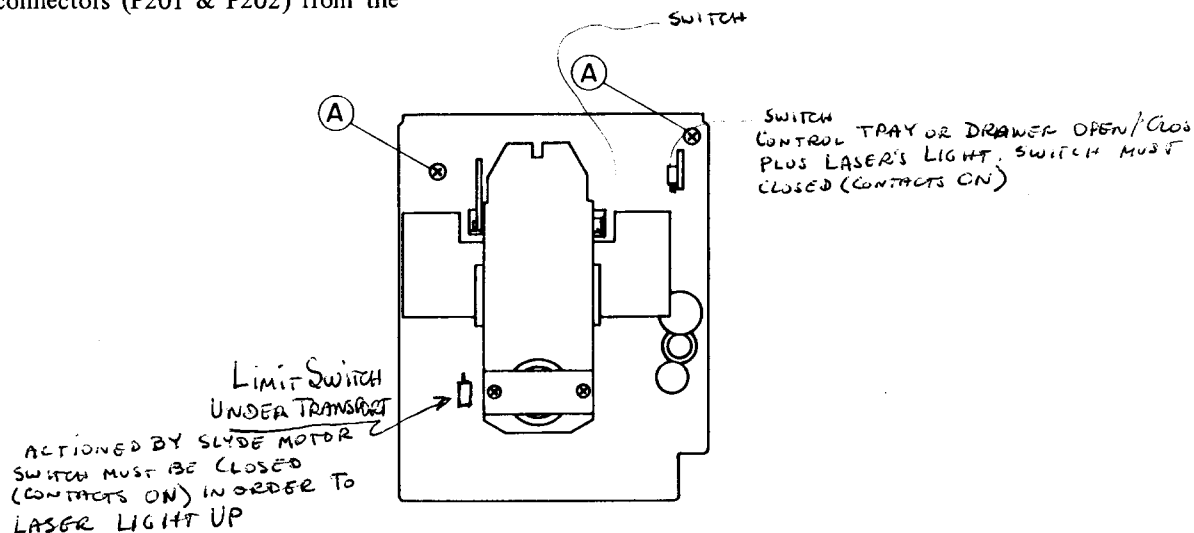

4. Arm P removal

- 1) Remove the top cover.
- 2) Remove a screw B from the bracket, holder.
- 3) Remove the arm P from the stopper.

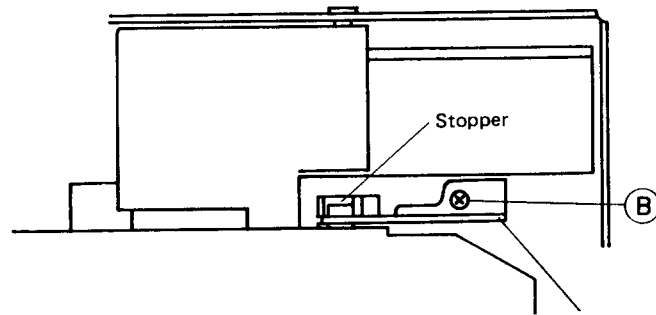

5. Replacing the spindle motor and turntable platter

- 1) Remove the tray and arm P.
- 2) Cut the points C of turntable platter with the pincers and pull it out from the shaft of spindle motor.
- 3) Remove the two screws D from the mechanical chassis.

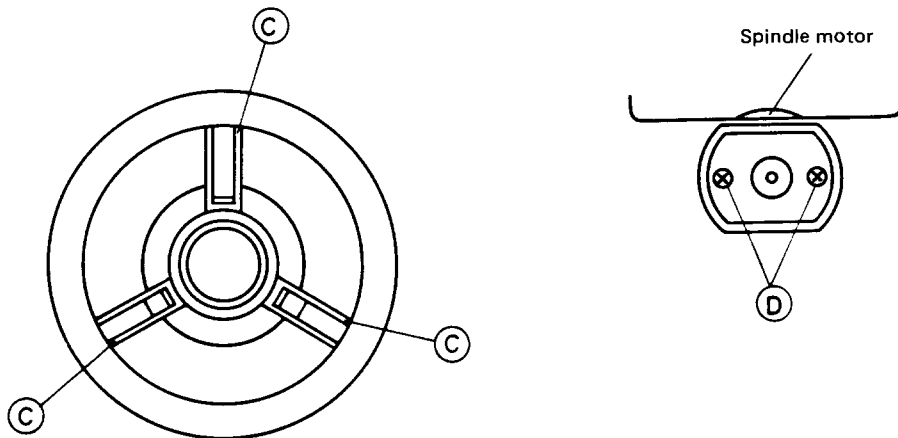

Press the center of turntable platter and insert the turntable platter in the shaft of spindle motor.

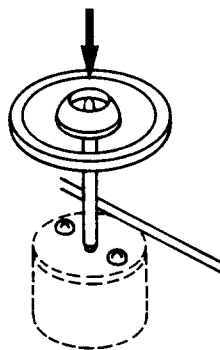

Height of turntable platter.

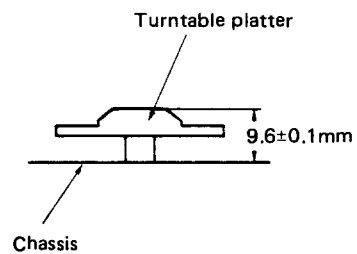

TROUBLE SHOOTING GUIDE

Load the disc on the tray, press OPEN/CLOSE key and close the tray. But, total play time and total number of tunes are not indicated on the fluorescent indicator tube.

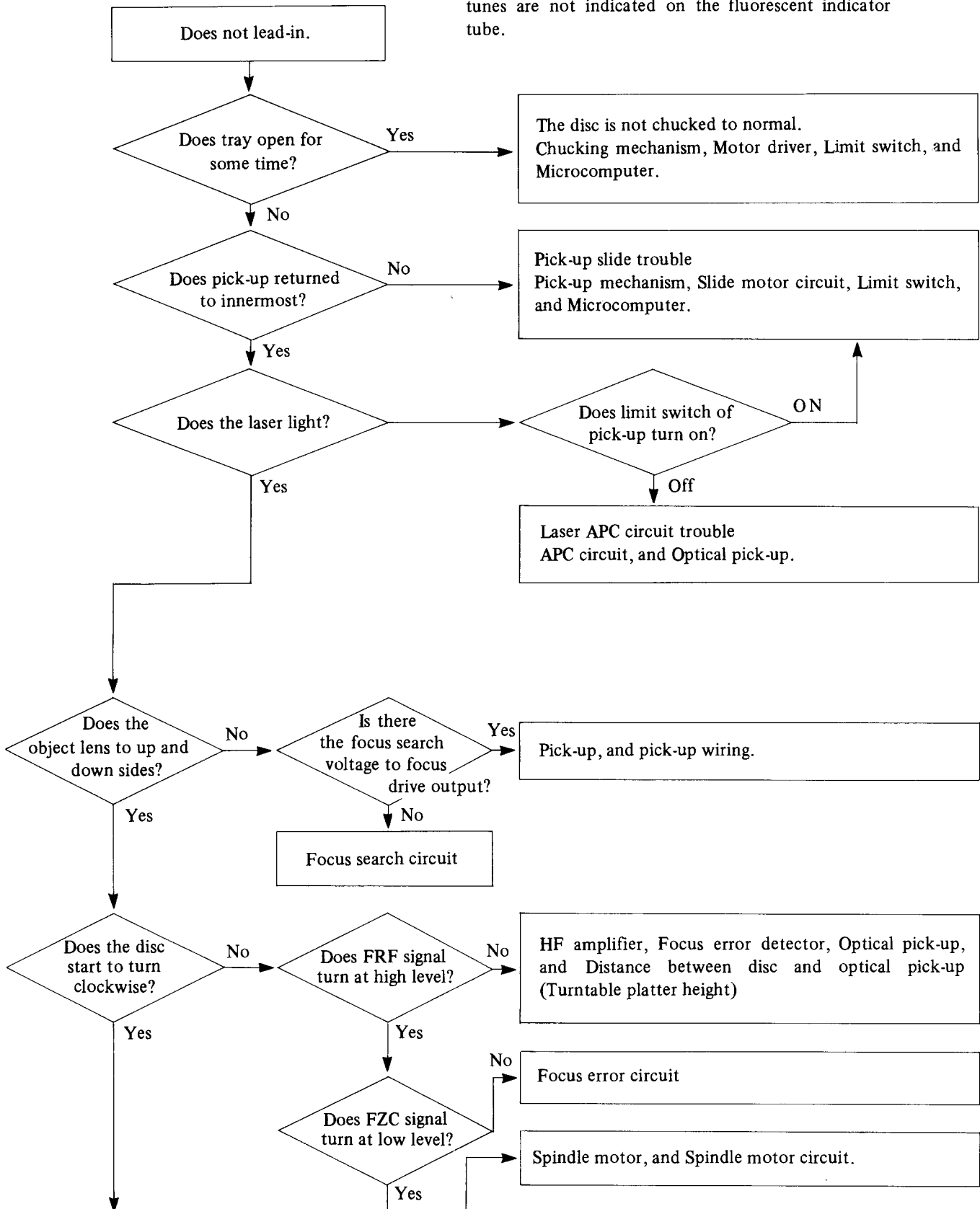

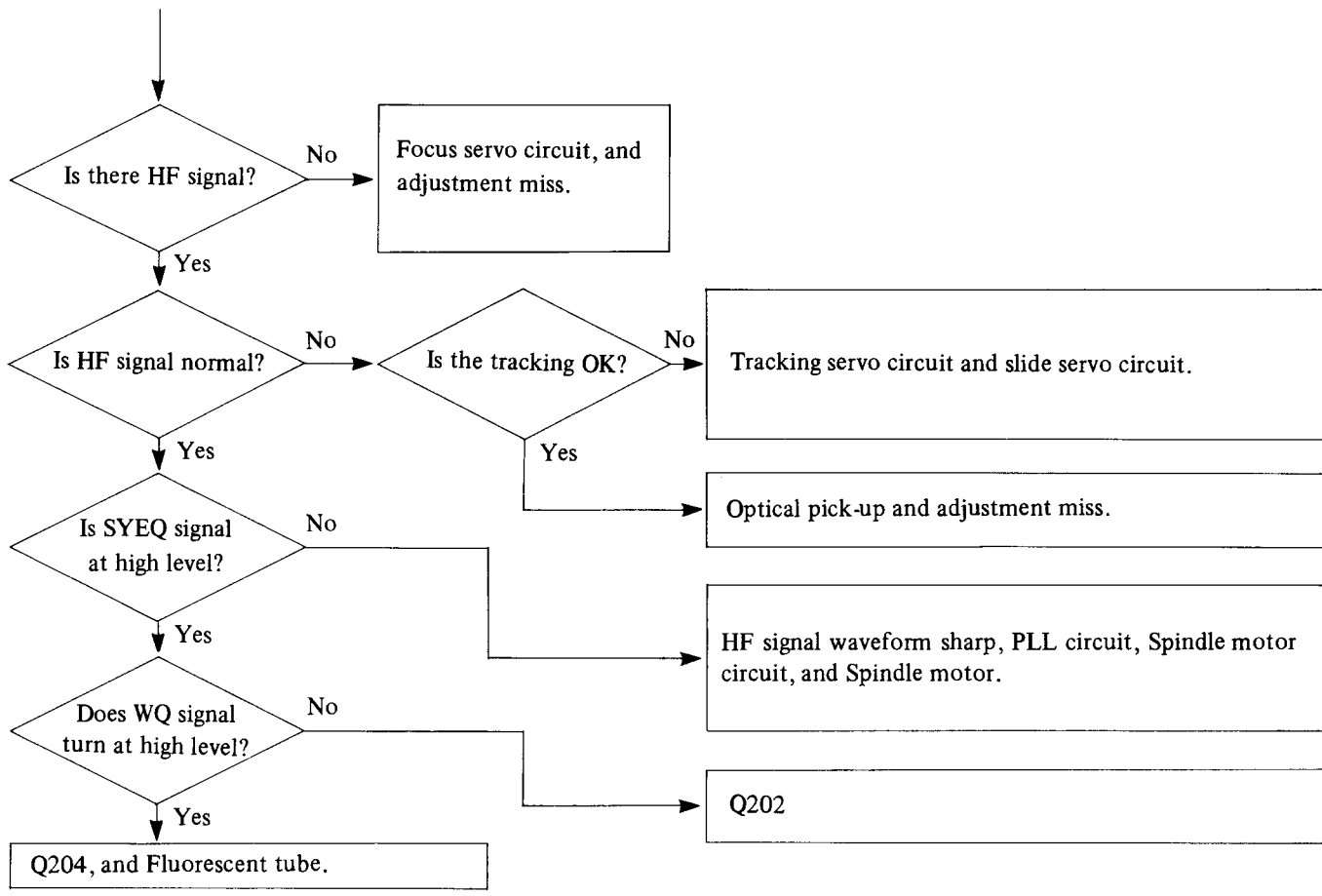

IC BLOCK DIAGRAM

PCM-56HP(D/A Converter) Q302

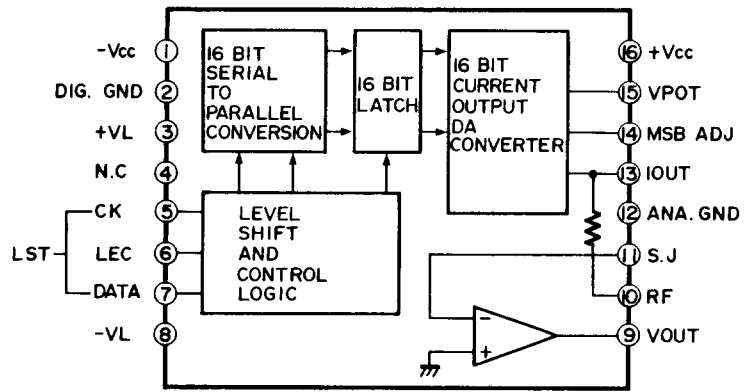

Pin No.	Designation	Function
1	-Vcc	Analog negative voltage
2	DIG GND	Digital circuit ground
3	+VL	Logic positive voltage
4	N.C	No connection
5	CK	Clock input
6	LEC	Latch enable control input
7	DATA	Data input
8	-VL	Logic negative voltage
9	Vout	Voltage output
10	RF	Feedback resistor
11	S.J	Summing junction (Op amp input)
12	ANA GND	Analog circuit ground
13	Iout	Current output
14	MSB ADJ	MSB adjustment terminal
15	VPOT	Potential meter terminal
16	+Vcc	Analog positive voltage

NJM-4558D(Operation Amplifier) Q101

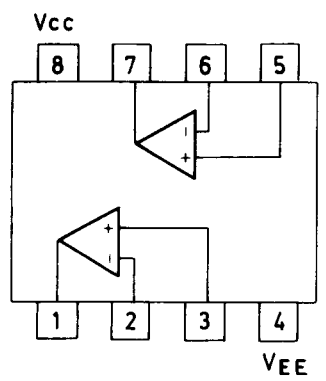

NJM-072BS(Operation Amplifier) Q309 Q310

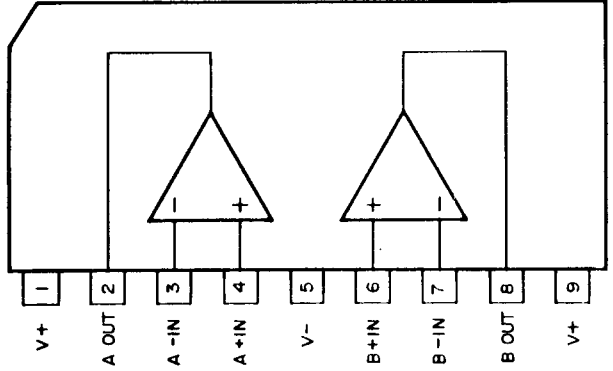

XB087A0(Servo Linear Circuit)

Q201

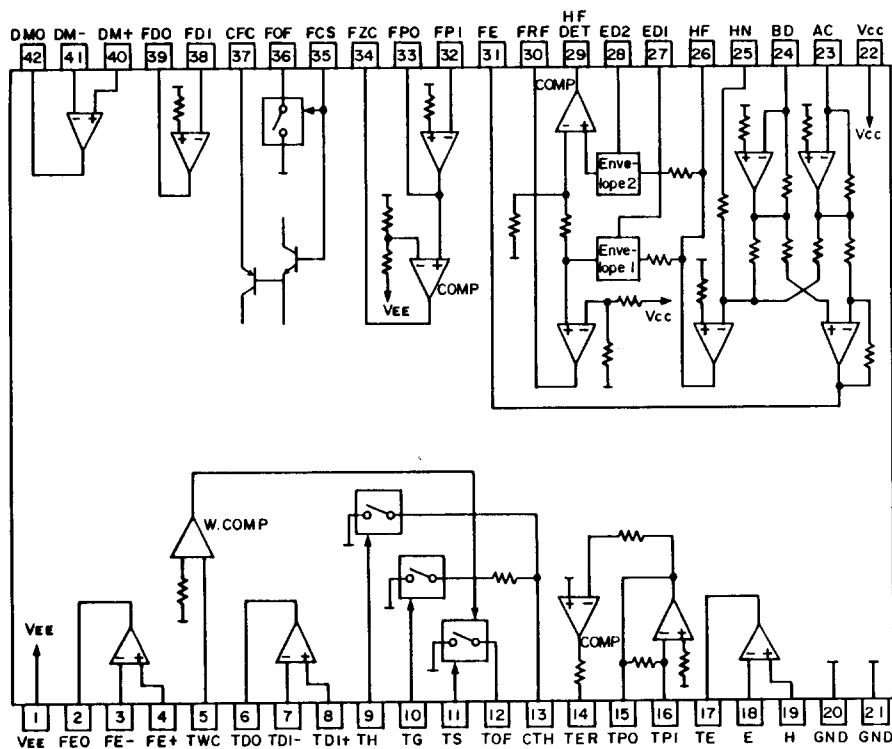

Pin No.	Designation	Function
2~4	FEO, FE-, FE+	Feed drive amplifier drives the feed power amplifier and is rotated the feed motor.
5	TWC	Terminal of tracking drive limiter to tracking coil. The reference voltage of this circuit is about $\pm 0.67V$.
6~19		Tracking servo system terminals.
6~8	TDo, TDi-, TDi+	Tracking drive amplifier drives the tracking power amplifier and actuates the tracking actuator.
9~11	TH, TG, TS	Tracking jump control switches. TH: Tracking hold switch TG: Gain control switch TS: Tracking offset switch
12~13	TOF, CTH	These terminals are controlled the tracking loop by TH, TG and TS (pins 9, 10, and 11).
14	TER	The output terminal of comparator of tracking zero cross.
15~16	TPo, TPI	Input/Output terminals of tracking preamplifier.
17~19	TE, E, F	This circuit is constituted by I-V conversion and differential amplifier. The reflected sub beams are converted into electric signals by the E and F, and the mutual differences are obtained as a tracking error signal.
23~39		Focus servo system terminals.
23~24	AC, BD	Input terminals from main spot of photo diode.
25~26	HN, HF	Feedback terminal and output terminal of HF (RF) signal.
27~28	ED1, ED2	Terminals for peak hold (pin 27) and bottom hold (pin 28) of HF (RF) signal.
29, 30, 34		Output terminals of servo IC to control the focus tracking.
29	HF	HF output is L level on the track of disc and H level on mirror section.
30	FRF	This circuit is the focus servo to on when comes the focus point from focus search condition.

Pin No.	Designation	Function
34	FZC	Use when the focus search. Same as above.
35	FCS	Signal input terminal to pull the focus.
36	FOF	Attenuator terminal.
37	CFC	Terminal to make the ramp waveform of focus search ramp circuit.
38~39	FDi, FDo	Input/output terminals of focus drive amplifier.
40~42	DM+, DM-, DMo	Input/output terminals of disc drive amplifier.

μ PD4053BC (Analog Switch)

Q303

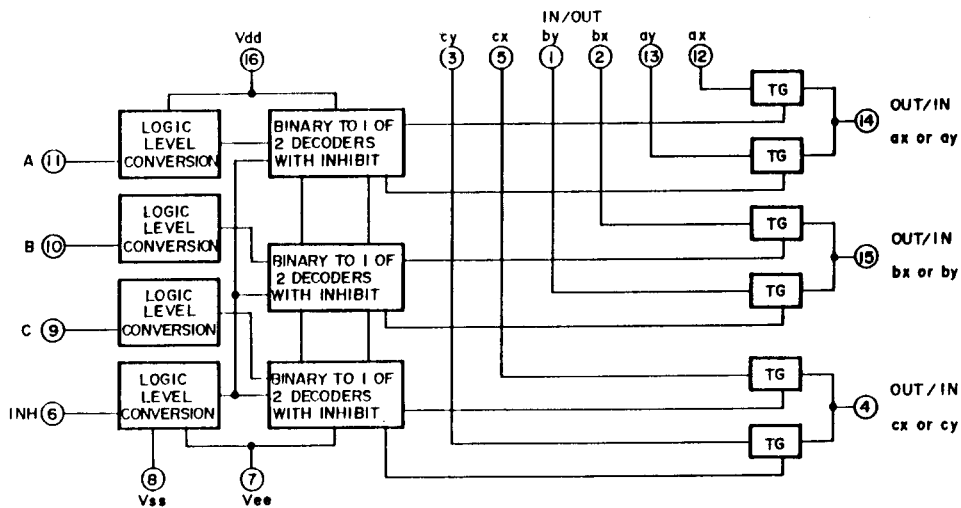

TP-1091 (Optical Device)

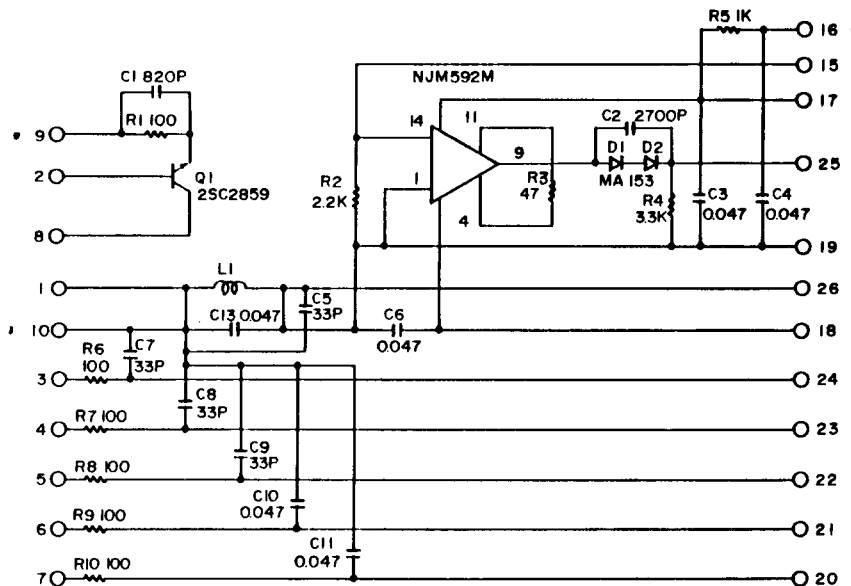

YM3815(Signal Processor & Controller)

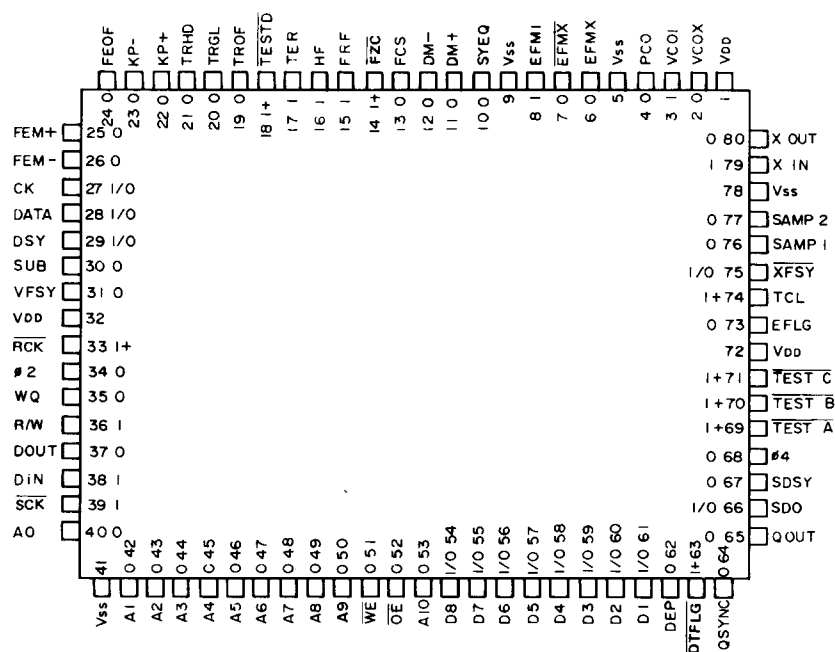

Pin No.	Designation	Function
79, 80	79 x IN and 80 x OUT	Clock Oscillator (8.6436MHz)
6~8	8 EFM1, 7 EFMX, and 6 EFMX	EFM External Circuit
2~4	4 PCO, 3 VCO1, 2 VCOX	Clock Regeneration Circuit
10	SYEQ	WYNC Match Signal
27~29	27 CK, 28 DATA, and 29 DSY	FM Demodulation Signal Check Output
30, 31, 33	30 SUB, 31 VFSY, and 33 RCK	Sub-code Output
35~37, 39	35 WQ, 36 R/W, 37 DOUT, and 39 SCK	Q-code Output related Pins
36, 38, 39	36 R/W, 38 DIN, and 39 SCK	μ COM Command related Pins
13~15	Input 14 FZC – 15 FRF, and Output 13 FCS	Focus Servo-mechanism related Pins
11, 12	11 DM+, and 12 DM-	Disc Servo-mechanism Pins
16, 17 19~23	Input 16 HF, and 17 TER Output 19 TROF, 20 TRGL, 21 TRHD, 22 KP+, and 23 KP-	Tracking Servo-mechanism related Pins
24~26	24 FEOF, 25 FEM+, and 26 FEM-	Feed Servo-mechanism related Pins
40, 42~61	40A0–53A10, 51 WE, 52 OE, and 54D8–61D1	RAM Connection
75	75 XFSY	Crystal Clock SYNC Signal
73	73 EFLG	C1 and C2 Error Correction Check Signal
34, 66, 67 69, 71, 63	34 ϕ 2, 66 SDO, SDSY, 63 DTFLG 69 TEST A, and 71 TEST C	DATA Control Circuit-Serial Signal Output
64, 65 68, 76, 77	65 Q OUT, 64 Q SYNC, 76 SAMP1, 77 SAMP, 2 and 68 ϕ 4	DAC Interface
62	62 DEP	De-emphasis Signal
8, 18 69~71	69 TEST A, 70 TEST B, 71 TEST C, 18 TEST D, and 8 TCL	Test Pins

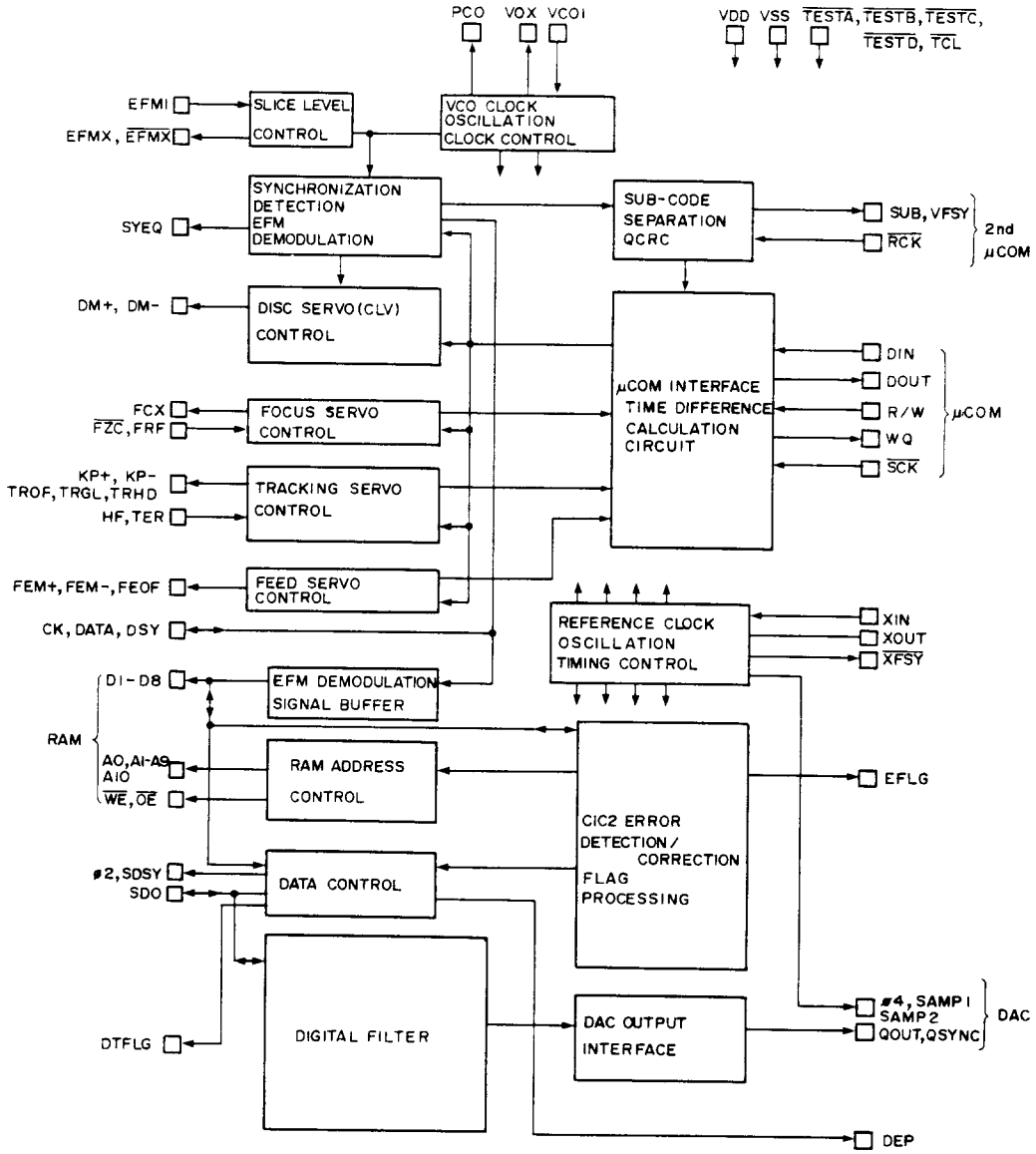

CXK5816M-15/HM6116P-4 (16bit RAM)

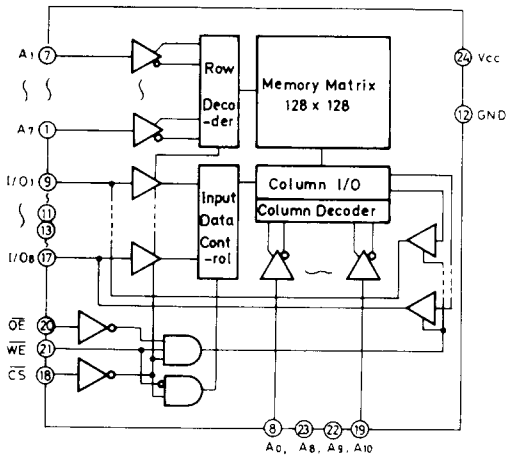

BA-6109 (Motor Driver)

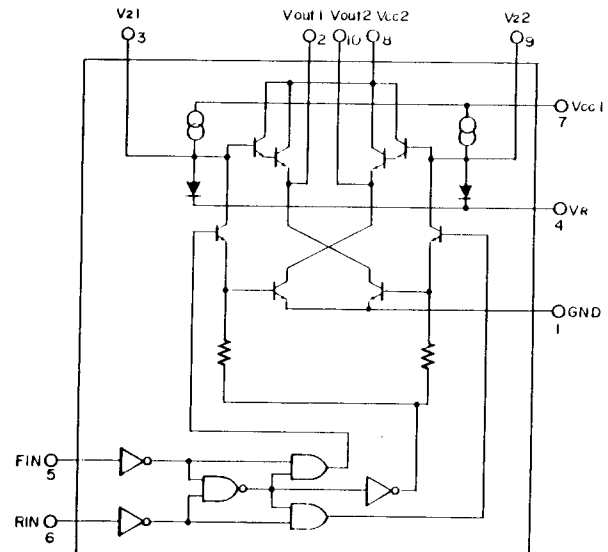

Connection of Micro Computer

Q204 TMP47C410AN-6078Z

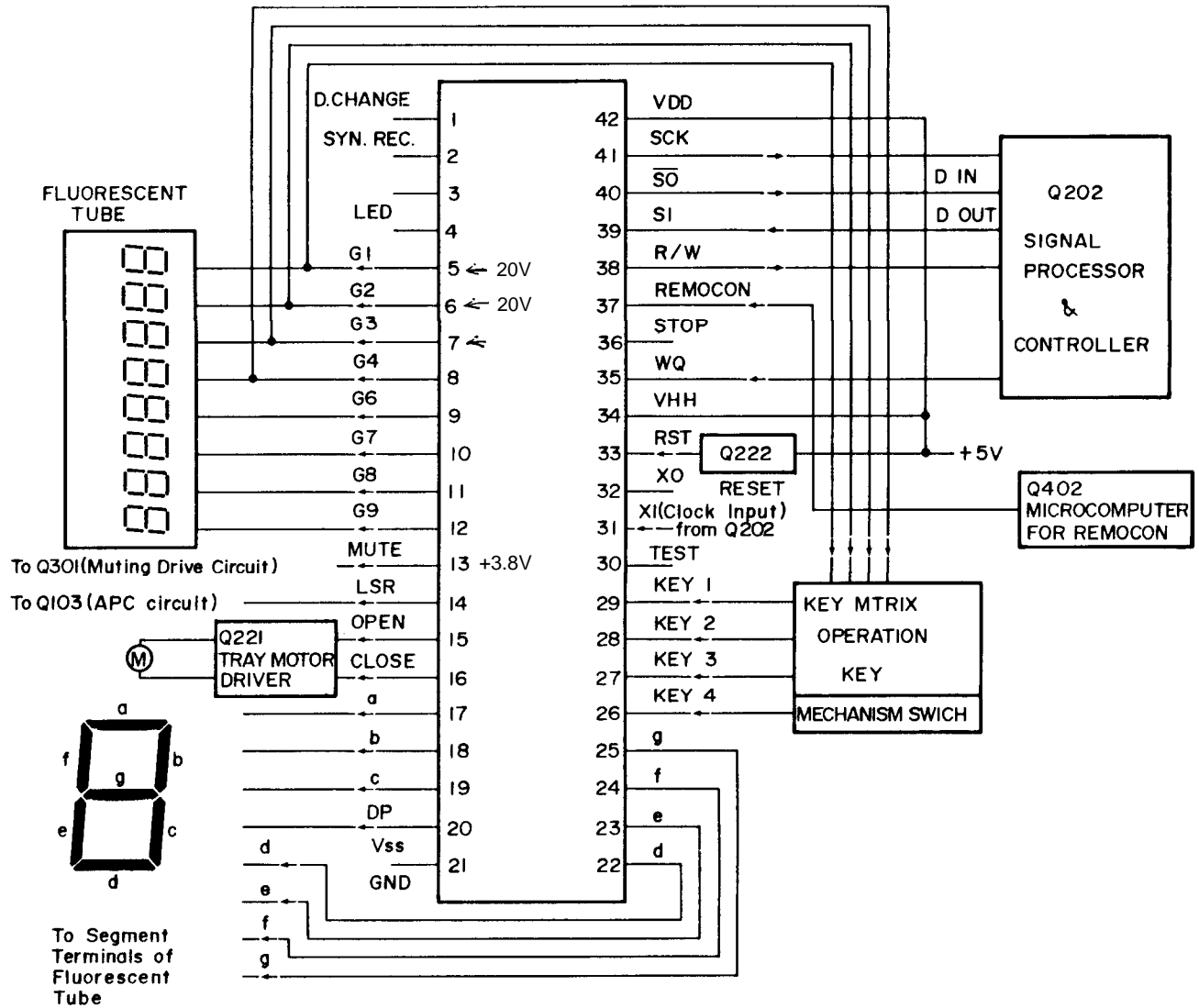

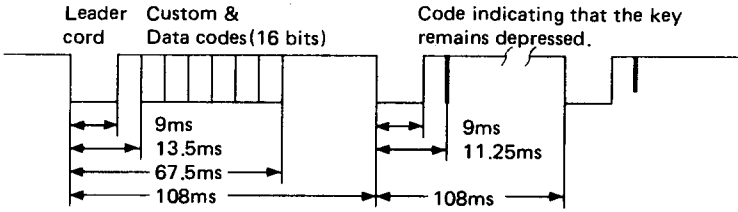
Pin NO.	Terminal	Description
5~8 9~12 17~19 20 22~25	G1-G4 G6-G9 a-c DP d-g	Control of fluorescent display tube is used the dynamic driver method. The digit datas of eight figures and eight segment datas are output from microcomputer.
13	MUTE	Audio muting control output for audio muting when the disc is stopped, and during accessing operations and pause mode. Muting is applied when the output is at high level.
14	LSR	Optical pick-up laser on/off control output. Laser is on when the output is at low level.
15 16	OPEN CLOSE	These signals used to control disc tray opening and closing operations. Control signals are passed direct from the microcomputer to pins 5 and 6 of the Q221 tray motor driver.
26	KEY 4	The condition of mechanical switches (open, close, and start) is processed, and data of switches is read by KEY 4 input port.
27~29	KEY 3-KEY 1	A 12(4x3) matrix is formed by using the digit datas. (Positive logic)
31	X1	Clock input from Q202.
33	RST	Using an IC designed specifically for microcomputer resetting, a reset output (low level) is applied to the microcomputer RST terminal when +5V line voltage drops below 4V reference voltage. This pin is normally switched on, and subsequently kept at high level.
37	REMOCON	Remote control input terminal. 
35	WQ	Write request: High level when transmit the information to micro computer.
38	R/W	Read/Write: High level when transmit the command from micro computer.
39	SI	Serial input: Transmit the servo system condition and sub-code data to micro computer.
40	SO	Serial output: Transmit the command data from micro computer to servo system.
41	SCK	Serial clock: Clock of serial data. Data is shifted at trailing edge.

ADJUSTMENT PROCEDURES

Instruments required

Dual trace oscilloscope, Frequency counter, CR oscillator, Test disc (SONY YEDS-18 TYPE4), Short clip, Resistor 1kohm

1. VCO frequency adjustment

Turn the power switch to ON.

Connect the frequency counter to the pin 2 (CK) of P203.

Connect the pins 1 (HF) and 2 (GND) with the short clip.

Adjust L201 until the frequency counter reading 4.32MHz.

After adjustment, remove the frequency counter and short clip. 600mv X 10 =6Vpp (Test probe X10 setting)

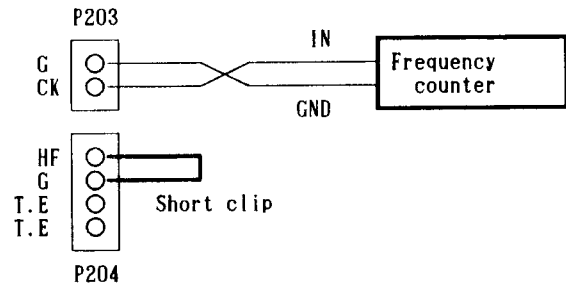

2. Focus offset adjustment

Load the test disc YEDS-18 and play back the track 2.

Connect the oscilloscope to pin 1 of P204.

Set R217 to mechanical center.

Adjust R217 until a clear trace of waveform pattern as shown photo 1 appear on the oscilloscope.

After adjustment, remove the oscilloscope.

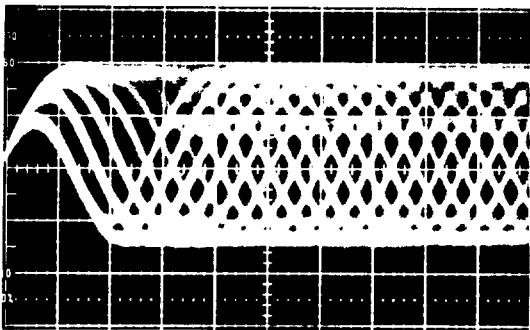
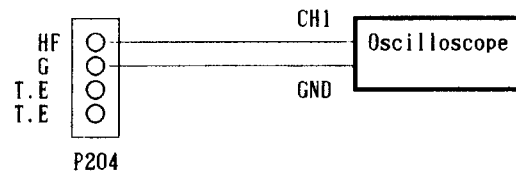

0.5V/div.
0.5μs/div.

Photo 1

3. Focus gain adjustment

Connect the dual trace oscilloscope to pins 1 (CH1) and 2 (CH2) of P205 at play condition.

Apply a sine wave 500mVp-p at 1kHz via resistor 1kohm from CR oscillator to pin 1 of P205.

Adjust R219 so that the waveforms of channel 1 and channel 2 become same level. (Refer photo 2).

After adjustment, remove the CR oscillator and oscilloscope.

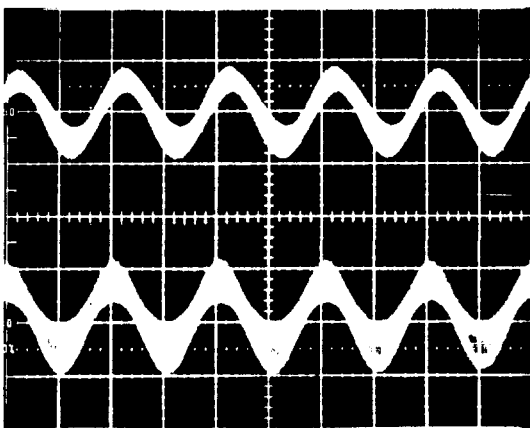
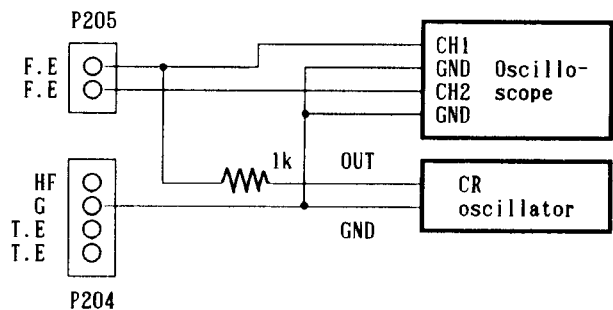

A=B Follow instruction and you can see waveform.

0.5V/div.
0.5ms/div.

Photo 2

PRINTED CIRCUIT BOARD-PARTS LIST

MAIN CIRCUIT PC BOARD(NAAR-2729-1)

CIRCUIT NO.	PART NO.	DESCRIPTION	CIRCUIT NO.	PART NO.	DESCRIPTION
					Photocoupler
			D301	225234	PCON-01 (C)
					X'tal
			X201	3010084	KD3492D-A
					Coils
			L201	232129	NSO-4045
			L301, L302	232131-1	NMC-6058
			L303, L304	231066	NCH-1118
					Capacitors
			C102	354742209	22 μ F, 16V, Elect.
			C103	354744709	47 μ F, 16V, Elect.
			C201	354721019	100 μ F, 6.3V, Elect.
			C205	354780339	3.3 μ F, 50V, Elect.
			C208	354780109	1 μ F, 50V, Elect.
			C210	354744709	47 μ F, 16V, Elect.
			C211	354780109	1 μ F, 50V, Elect.
			C220	354721019	100 μ F, 6.3V, Elect.
			C221	354741009	10 μ F, 16V, Elect.
			C222	354780229	2.2 μ F, 50V, Elect.
			C223	354744709	47 μ F, 16V, Elect.
			C224	354783399	0.33 μ F, 50V, Elect.
			C225	354780479	4.7 μ F, 50V, Elect.
			C242	354780109	1 μ F, 50V, Elect.
			C244	354744709	47 μ F, 16V, Elect.
			C245	354721019	100 μ F, 6.3V, Elect.
			C260	354744709	47 μ F, 16V, Elect.
			C301, C302	372524714	470pF \pm 5%, 50V, Styrol
			C313, C314	352942206	22 μ F, 16V, Non-polar elect.
			C315, C316	372522214	220pF \pm 5%, 50V, Styrol
			C321	354783399	0.33 μ F, 50V, Elect.
			C322, C323	354741009	10 μ F, 16V, Elect.
			C324	354741019	100 μ F, 16V, Elect.
			C327	354741009	10 μ F, 16V, Elect.
			C329, C330	354741009	10 μ F, 16V, Elect.
			C901, C902	354742229	2,200 μ F, 16V, Elect.
			C903, C904	354721019	100 μ F, 6.3V, Elect.
			C907, C908	354761019	100 μ F, 35V, Elect.
			C951, C952	354751029	1,000 μ F, 25V, Elect.
			C953, C954	354741019	100 μ F, 16V, Elect.
			C955, C956	354742219	220 μ F, 16V, Elect.
			C959, C960	354744709	47 μ F, 16V, Elect.
					Resistors
			R217, R273	5210064	N06HR103BD, Semi-fixed
			R219, R269	5210070	N06HR104BD, Semi-fixed
			R279	5210070	N06HR104BD, Semi-fixed
			R294	49163103404	10kohm \times 4, 1/10W, Network
			R295	49163392404	3.9kohm \times 4, 1/10W, Network
			R2003	49163103404	10kohm \times 4, 1/10W, Network
			R301	5210007	N06HR1KBDM, Semi-fixed
			R907	441623904	39ohm, 1W, Metal oxide film
			R908	441622704	27ohm, 1W, Metal oxide film
					Plugs
			P101	25055153	NPLG-9P-137 2000627
			P102	25055152	NPLG-8P-136
			P203	25055146	NPLG-2P-130
			P204	25055148	NPLG-4P-132
			P205	25055146	NPLG-2P-130
			P302	25055133	NPLG-3P-117
					Sockets
			SC201	2000444	NSAS-5P-403
			SC202	2000583	NSAS-4P-539
			P206, P207	25050272	NSCT-8P-100
					ICs
					Transistors
					Diodes
					Photocoupler
					X'tal
					Coils
					Capacitors
					Resistors
					Plugs
					Sockets
					ICs
					Transistors
					Diodes
					Photocoupler
					X'tal
					Coils
					Capacitors
					Resistors
					Plugs
					Sockets
					ICs
					Transistors
					Diodes
					Photocoupler
					X'tal
					Coils
					Capacitors
					Resistors
					Plugs
					Sockets
					ICs
					Transistors
					Diodes
					Photocoupler
					X'tal
					Coils
					Capacitors
					Resistors
					Plugs
					Sockets
					ICs
					Transistors
					Diodes
					Photocoupler
					X'tal
					Coils
					Capacitors
					Resistors
					Plugs
					Sockets
					ICs
					Transistors
					Diodes
					Photocoupler
					X'tal
					Coils
					Capacitors
					Resistors
					Plugs
					Sockets
					ICs
					Transistors
					Diodes
					Photocoupler
					X'tal
					Coils
					Capacitors
					Resistors
					Plugs
					Sockets
					ICs
					Transistors
					Diodes
					Photocoupler
					X'tal
					Coils
					Capacitors
					Resistors
					Plugs
					Sockets
					ICs
					Transistors
					Diodes
					Photocoupler
					X'tal
					Coils
					Capacitors
					Resistors
					Plugs
					Sockets
					ICs
					Transistors
					Diodes
					Photocoupler
					X'tal
					Coils
					Capacitors
					Resistors
					Plugs
					Sockets
					ICs
					Transistors
					Diodes
					Photocoupler
					X'tal
					Coils
					Capacitors
					Resistors
					Plugs
					Sockets
					ICs
					Transistors
					Diodes
					Photocoupler
					X'tal
					Coils
					Capacitors
					Resistors
					Plugs
					Sockets
					ICs
					Transistors
					Diodes
					Photocoupler
					X'tal
					Coils
					Capacitors
					Resistors
					Plugs
					Sockets
					ICs
					Transistors
					Diodes
					Photocoupler
					X'tal
					Coils
					Capacitors
					Resistors
					Plugs
					Sockets
					ICs
					Transistors
					Diodes
					Photocoupler
					X'tal
					Coils
					Capacitors
					Resistors
					Plugs
					Sockets
					ICs
					Transistors
					Diodes
					Photocoupler
					X'tal
					Coils
					Capacitors
					Resistors
					Plugs
					Sockets
					ICs
					Transistors
					Diodes
					Photocoupler
					X'tal
					Coils
					Capacitors
					Resistors
					Plugs
					Sockets
					ICs
					Transistors
					Diodes
					Photocoupler
					X'tal
					Coils
					Capacitors
					Resistors
					Plugs
					Sockets
					ICs
					Transistors

CIRCUIT NO.	PART NO.	DESCRIPTION
P208, P901 P951	25050269 25050267	NSCT-5P-97 NSCT-3P-95
	Terminal	
P301	25045180	NPJ-2PDBL70, Output
	Radiator	
	27160029	RAD-07
	Bracket	
	27141059	Ground
	Screw	
	82143006	3P+6FN(BC)

HEADPHONE AMPLIFIER PC BOARD (NAHP-2730-1/1A)

CIRCUIT NO.	PART NO.	DESCRIPTION
Q371	222654	NJM4556D, IC
C371, C372	354741009	10 μ F, 16V, Elect. capacitor
R371, R372	5104172	N09RGL20KB15, Variable resistor
P371	25045139	HLJ0540-01-010, Headphone terminal
SC371	2000538B	NSAS-3P494, Socket

DISPLAY PC BOARD(NADIS-2736-1)

CIRCUIT NO.	PART NO.	DESCRIPTION
U401	241068	BX-1407, Photo receiving unit, remote control
Q401	212034	FIP-9ST-68ZAK, Fluorescent indicator tube
Q402	222989	TMP42C60P-5354, IC
D401-D404	223145 or	1S2076 or
D406	223150	US-1040, Diodes
C401	354780479	4.7 μ F, 50V, Elect. capacitor
R401, R402	49121104408	100kohm \times 8, 1/8W, Network resistor
S401-S412	25035389 28140501	NPS-111-S353, Push switches t4.5 \times 10 \times 40mm, Cushion

POWER SWITCH PC BOARD(NAPS-2737-1)

CIRCUIT NO.	PART NO.	DESCRIPTION
C801	3500065 A	Δ DE7150FZ103PCSA, Capacitor IS
S801	25035398 27300601 25060092	Δ NPS-111-S362P, Power switch Δ Cover for C801 NTM-1S33, Terminal

TERMINAL PC BOARD(NATRM-2844-1)

CIRCUIT NO.	PART NO.	DESCRIPTION
P201	25055135	NPLG-5P-119, Plug
P202	25055148 25060092	NPLG-4P-132, Plug Terminals

SWITCH PC BOARDS (NASW-2845-1/2846-1/2847-1)

CIRCUIT NO.	PART NO.	DESCRIPTION
S841	25065261	NMS-1212, Microswitch, start
S821	25065260	NMS-1211, Microswitch, open
S831	25065261	NMS-1212, Microswitch, close

MOTOR DRIVER CIRCUIT PC BOARD (NAAR-2854-1)

CIRCUIT NO.	PART NO.	DESCRIPTION
Q213, Q215	2200783 or 2200784	2SD669(C) or 2SD669(D), Transistors
P209, P210	25050267 27160029 82143006	NSCT-3P95, Sockets RAD-07, Radiators 3P+6FN(BC), Pan head screws